

**JetCon 2302**  
**Industrial 2-Channel**  
**Fast Ethernet to Fiber Media Converter**

**Quick Installation Guide**

V1.1 26-Aug,2010  
[www.korenix.com](http://www.korenix.com)

## Introduction

JetCon 2302 is a Fast Ethernet to Fiber Media Converter with 2 Fast Ethernet copper and 2 fiber ports allowing the device to act as 4 port Fast Ethernet Fiber switch or 2-channel Converter for flexible industrial applications. In switch mode, JetCon 2302 is an industrial 4-port 10/100Mbps Fast Ethernet Switch, incorporating 3.2Gbps switching fabric with non-blocking store and forward technology to fulfill the high transmission performance requirements. In converter mode, JetCon 2302 is a cost effective industrial 2-channel 10/100TX to 100FX media converter with an error packet filtering function. It also provides relay alarm output function for the port and power alert. The NEMA TS2 compliant JetCon 2302, designed with IP31 grade enclosure, is equipped with dual redundant DC10~60V power inputs and provides 1.5 K Hi-Pot isolation protection and wide operating temperature, therefore ensuring highly reliable network performance under harsh industrial environments with vibration and shock.

## Package Checklist

Unpack the box and you will find:

- JetCon 2302 x1
- Quick Installation Guide



JetCon 2302



QIG

## Mounting the Unit

Din-Rail mount: Mount the din-rail clip screwed on the rear of JetCon 2302 on the DIN rail.

For information about the DIN Rail installation, please refer to user's manual.

The user manual can be downloaded from the Korenix Website as below:

<http://www.korenix.com/downloads.htm>



## Wiring the Power Inputs

1. Insert the positive and negative wires into the V+ and V- contact on the terminal block connector.
2. Tighten the wire-clamp screws to prevent the DC wires from being loosened.
3. Both of the redundant power inputs accept negative or positive type power source; the negative power source is commonly used in telecom applications. See the figure-1 and figure-2 for the power wiring.

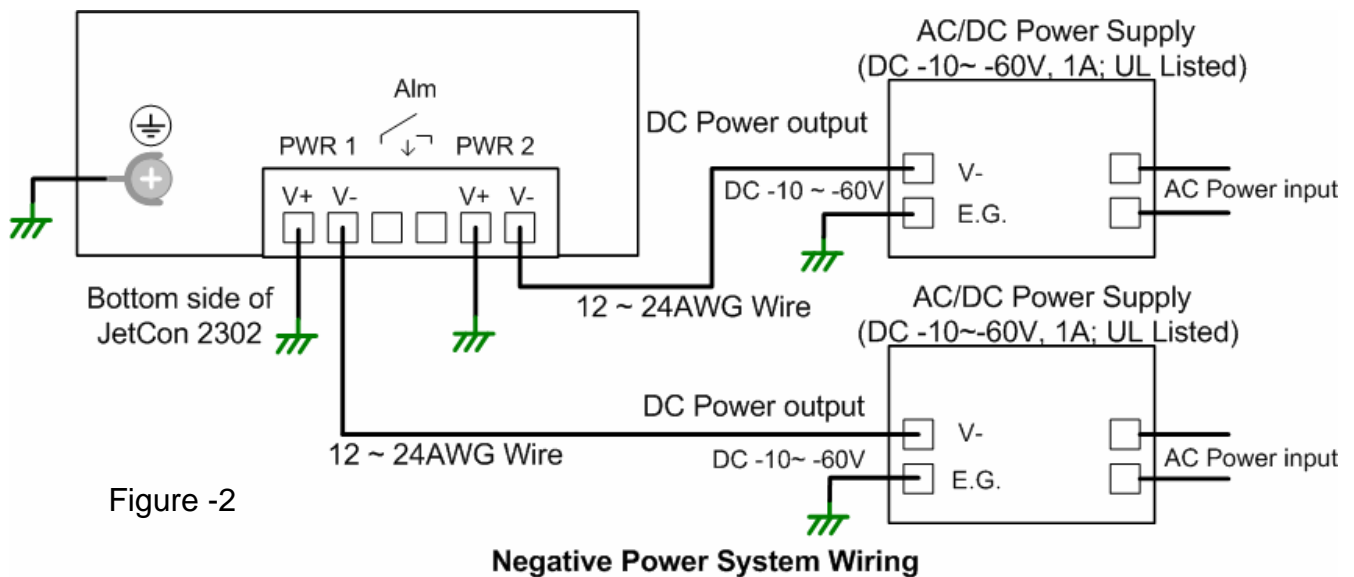
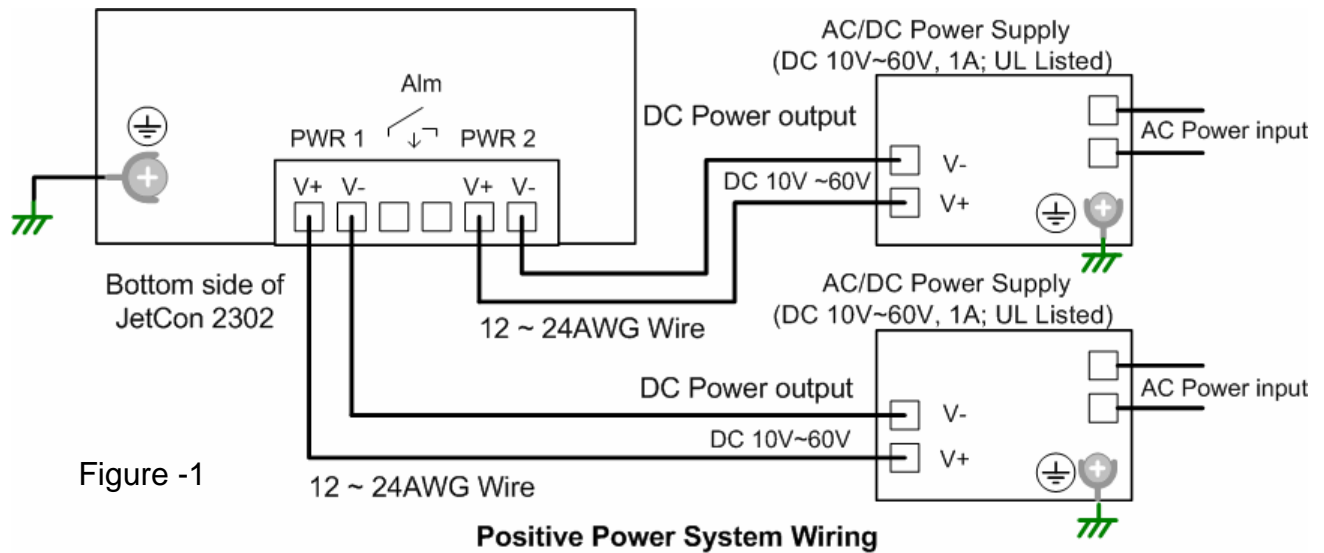

**Note:** The recommended working voltage is DC24V (DC10~ 60V); both power inputs should apply with the same power system; either positive or negative.

### Wiring the Relay Output and Chassis Grounding

The relay output alarm contacts are in the middle of the terminal block connector as shown in the figure below.

By inserting the wires and setting the DIP switch of the respective Port Alarm to “ON”, relay output alarm will detect any port failure and form a short circuit. The alarm relay output is “Normal Open”. Please refer to Figure -3 for the relay wiring architecture.

In an industrial environment there might be a lot of devices that generate electromagnetic noise, such as AC motors, electric welding machines and power generators. These devices will generate electric noise or surges that might disturb communication. To prevent these interferences, the JetCon 2302 should be well earthed.

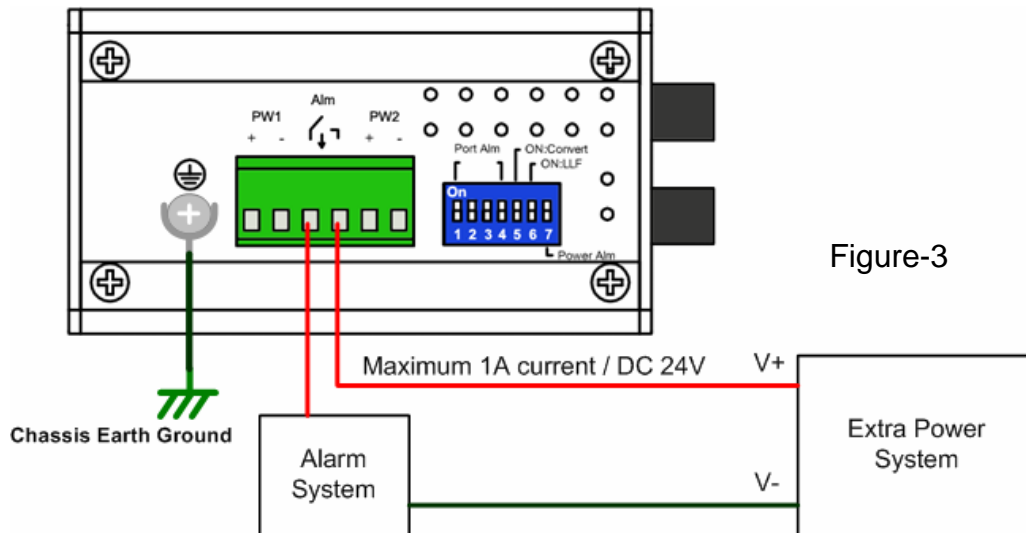

## Connecting to Network

1. **Connecting the Ethernet Ports:** Connect the Ethernet RJ-45 port to another networking device by properly twisted cable (UTP or STP). If the port is well linked with partner, the Link LED (Green) will turn on and the Activity LED will start blinking slowly when the packets are transmitting and receiving. The RJ-45 ports support MDI/MDI-X function.
2. **Connecting the Fiber Port:** Connect the fiber port to fiber link partner by proper fiber cable as shown in the Figure-4. Ensure that both of connected fiber ports are the same type and use exactly optical fiber cable.

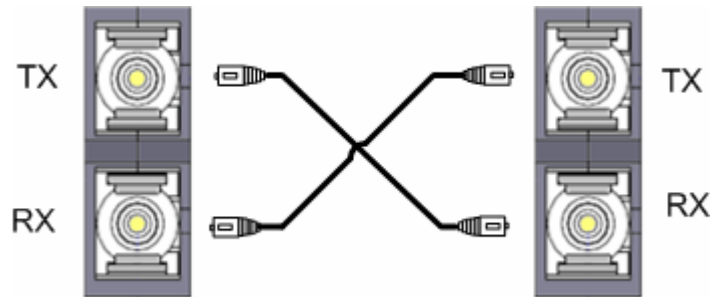



Figure-4

<b>ATTENTION</b>	<b>This is a Class 1 Laser/LED product.</b>
	<b>Don't stare into the Laser/LED Beam.</b>

### Operating Mode Selection

The JetCon 2302 is not only a 4-port Switch, but it is also a 2-channel Fast Ethernet Media Converter. It is configured by the DIP switch and activated through the power resetting or the reset button.

To understand the functions of the Switching and converter modes, refer to the table below:

	Switching mode	Converter mode
Data exchange	Yes	No. Port 1, 3 grouped as a single channel A. Port 2, 4 grouped as a single channel B.
Forward Technology	Store and forward	Store and forward.
Port Event Alarm	Fully supported	Fully supported.

### DIP Switch Setting

DIP switch	Status	Description
DIP 1~4	ON	Port link down event alarm enabled.
	Off	Port link down event alarm disabled. (Default)
DIP 5	ON	Enabled Converter mode
	Off	Switch mode. (Default)
DIP 6	ON	Enabled power event alarm
	Off	Disabled power event alarm (Default)
DIP 7	N/A ( Not Aavailable)	

**LED indicators**

<b>Indicators</b>	<b>LED color</b>	<b>Description</b>
<b>Ethernet RJ-45</b>	Green	Green on: the port is linked well with partner
	Yellow	Green blinking: the port is transmitting packet.
<b>Fiber</b>	Green	Green on: the port is linked well with partner.
	Yellow	Green blinking: the port is transmitting packet.
<b>PWR 1,2</b>	Green	Green on: the power is on applying.
<b>Alm</b>	Red	Red on: port link down or power off event occurred, and the alarm relay output conductors formed a short circuit.
<b>Con.</b>	Green	Green on: the device is setting on the converter mode.

**Korenix Customer Service**

KoreCARE is Korenix Technology's global service center, where our professional staff is ready to solve your problems at any time

Korenix global service center's e-mail is [KoreCARE@korenix.com](mailto:KoreCARE@korenix.com)